

PARTS LIST			
ITEM	QTY.	PART NAME	MATERIAL
1	1	TOP PLATE	MALLEABLE IRON
2	1	WHEEL	MALLEABLE IRON
3	2	AXLE SUPPORT	MALLEABLE IRON
4	1	AXLE	SAE 1020
5	2	BUSHING	BRONZE

FIT	BETWEEN PARTS
H8/f7	4 AND 5
H7/p6	3 AND 5
H8/F7	2 AND 4

DDGT
DIGITAL DESIGN
GRAPHICS
TECHNOLOGY
WWW.DDGT.NET
GENERAL NOTES:
FASTEN ASSEMBLY
TO A 6MM STEEL
PLATE BY FOUR
M10 X 40MM LONG
HEX HEAD BOLTS,
NUTS, AND
WASHERS.
ROUNDS AND
FILLETS R3

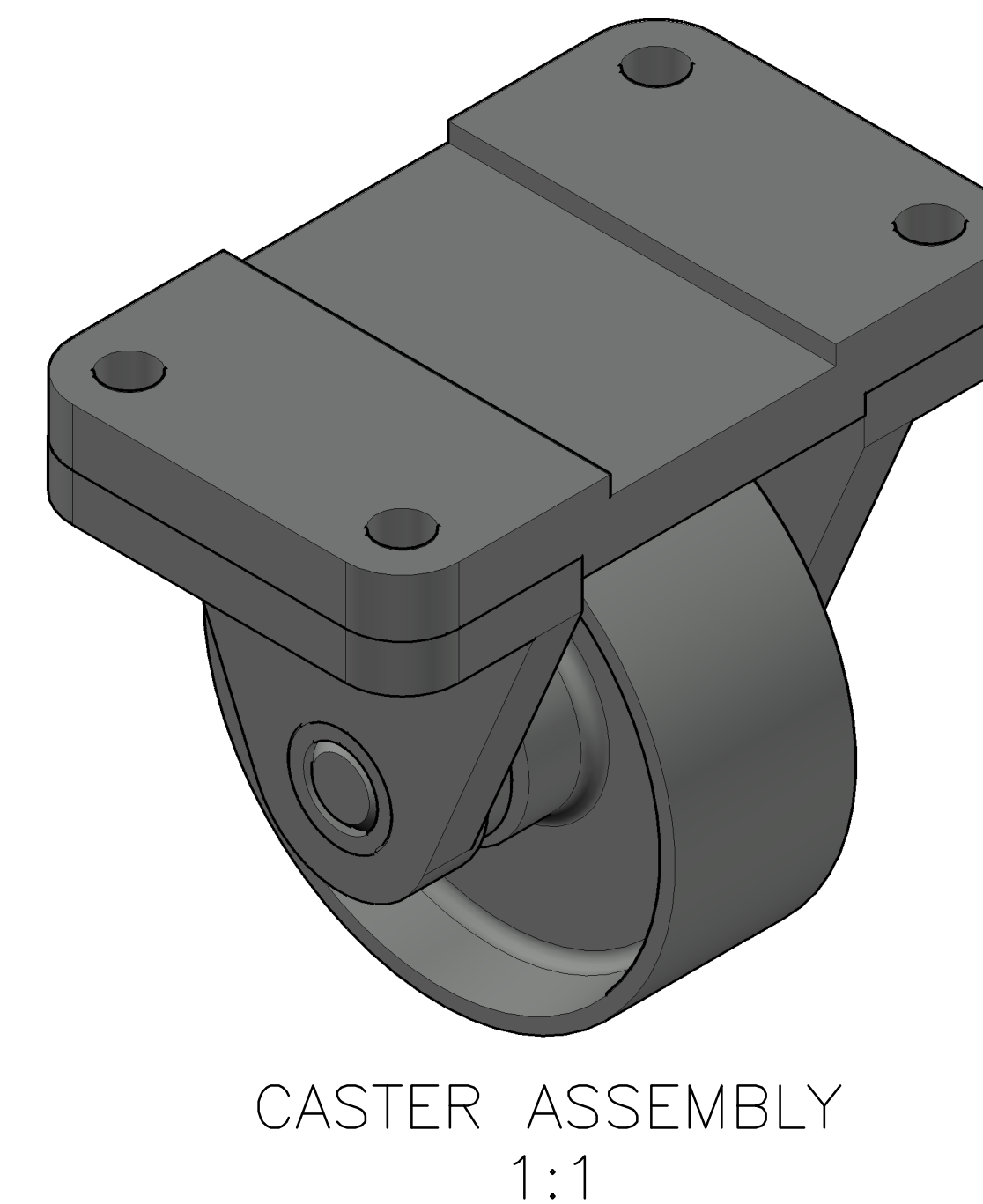
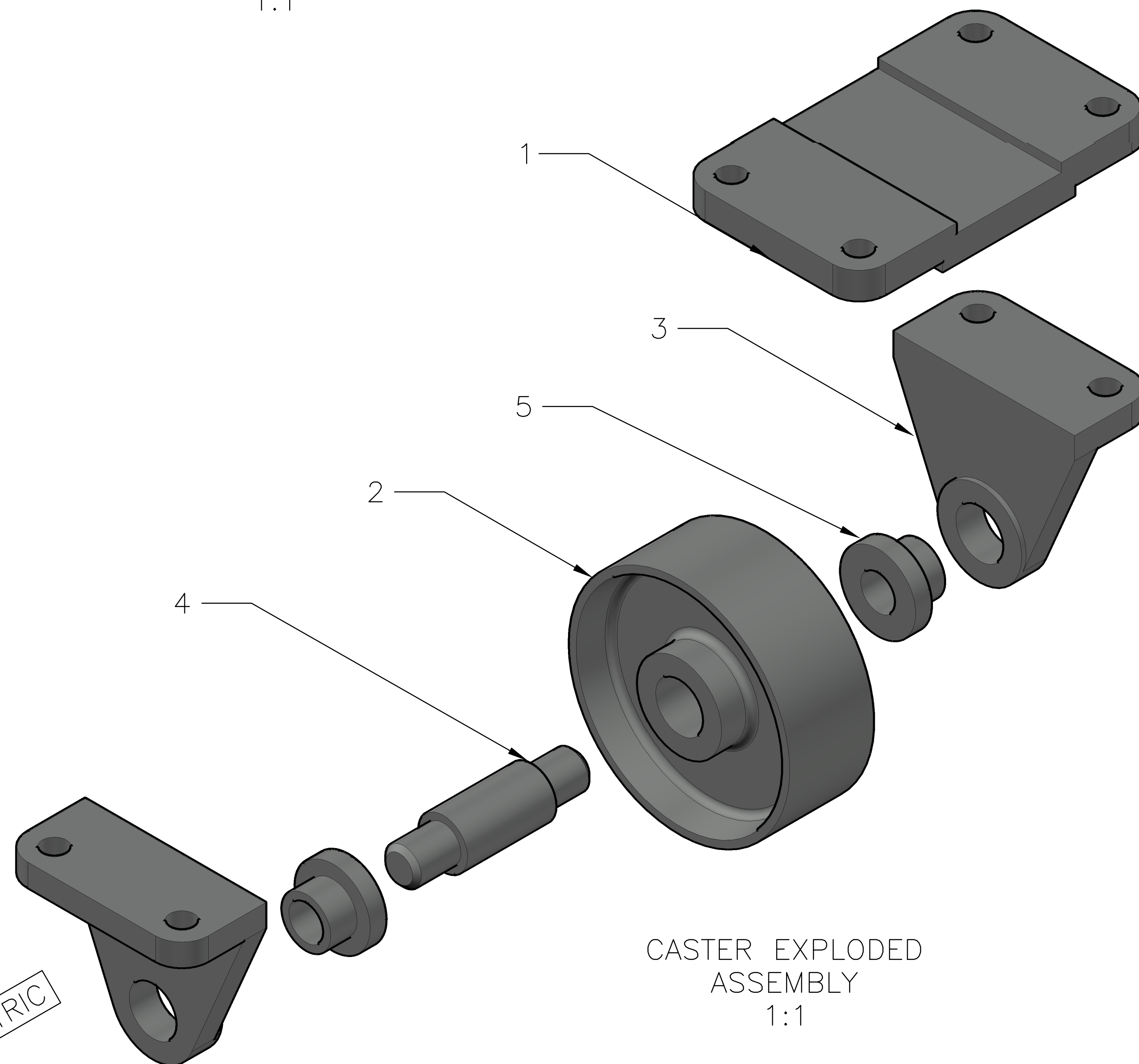
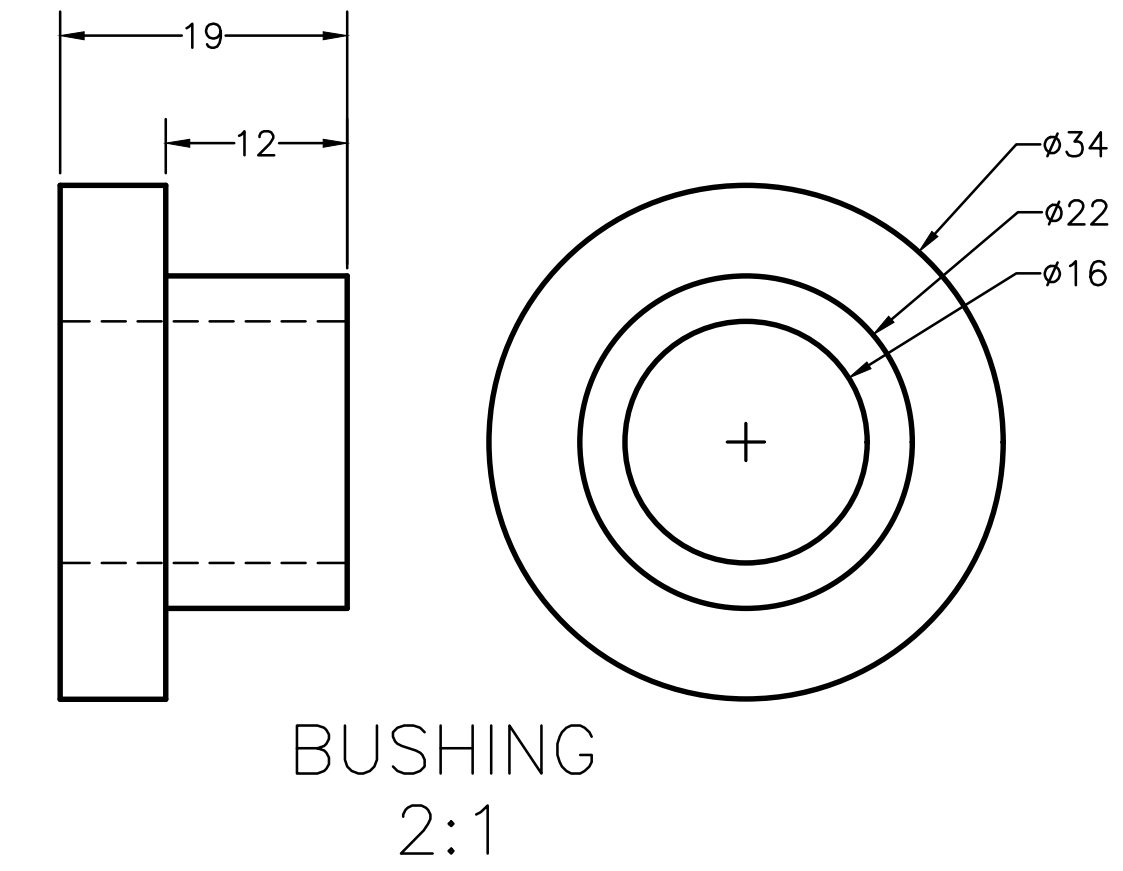
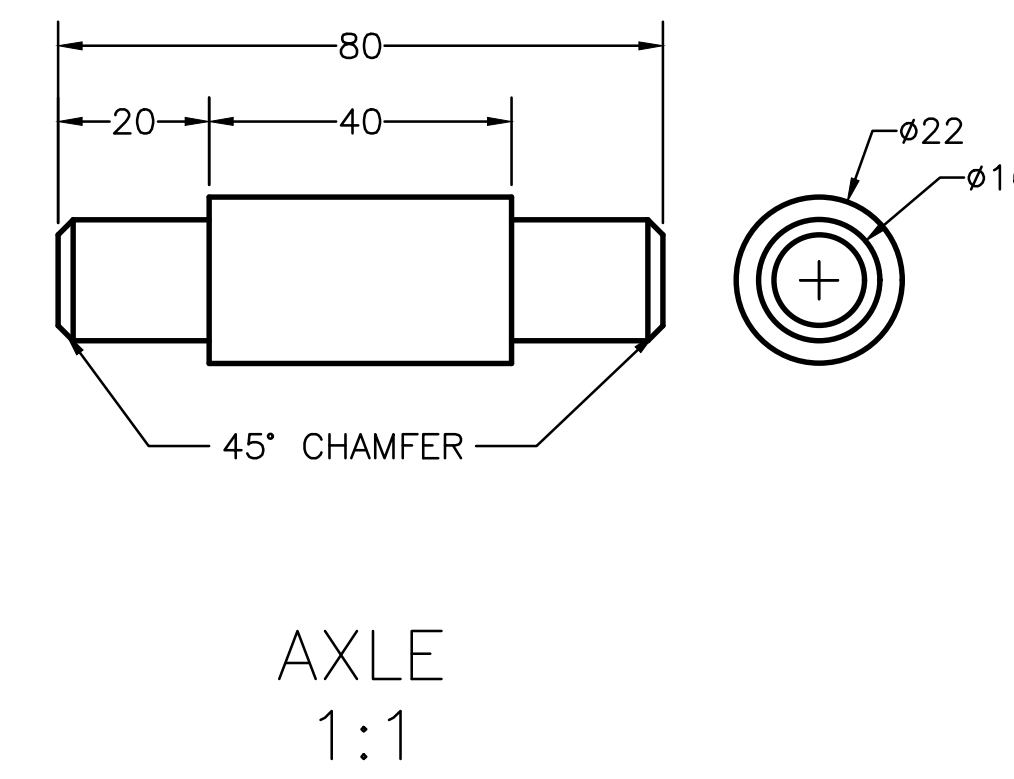

METRIC

LEGEND:
Ø DIAMETER
R RADIUS
| SPOTFACE/COUNTERBORE

LOVES 3D PRINTING & DESIGN
KEN LOVE OWNER
lov3dprinting@gmail.com
www.ddgt.net/StudentPages/love

TOLERANCES UNLESS SPECIFIED:
MILLIMETERS: ±.5
WHOLE NUMBERS: ±.25
FRACTIONAL: ±1/64"
ANGLES ±1 DEGREE
SURFACES 3/2

CLASS: DDGT 120
ASSIGNMENT #: 63
AUTOCAD DRAWING NAME: CASTER ASSEMBLY
FIG #: 9-51
MANAGER: G. STROMMEN
DRAFTER: K LOVE
DATE: 4/20/23
SCALE: AS NOTED
PAGE #: 1 OF 1